

15U 550 X 500 MM



EXECUTIVE MODEL



FEATURES

- ◆ 19" Standard as DIN 41494/Equivalent | State-of-the art HiTech Manufacturing & Quality Management System
- ◆ Convenient Wall mounting with Additional provision for Floor mounting & Table mounting options.
- ◆ Front Toughened Glass Door & Side ventilated steel doors with lock & key, Back ventilated removable Panel
- ◆ SPCC Quality Cold Rolled Sheet, Welded Frame, Exquisite Design, Reliable structure & High Craftmanship
- ◆ Powder coated with Ten tank pretreatment process meeting ASTM std Frame RAL 7035 Door RAL 7037
- ◆ Numbered U positions | Cable entry on Top & Bottom with Cromet | Turing angle of front door over 180°

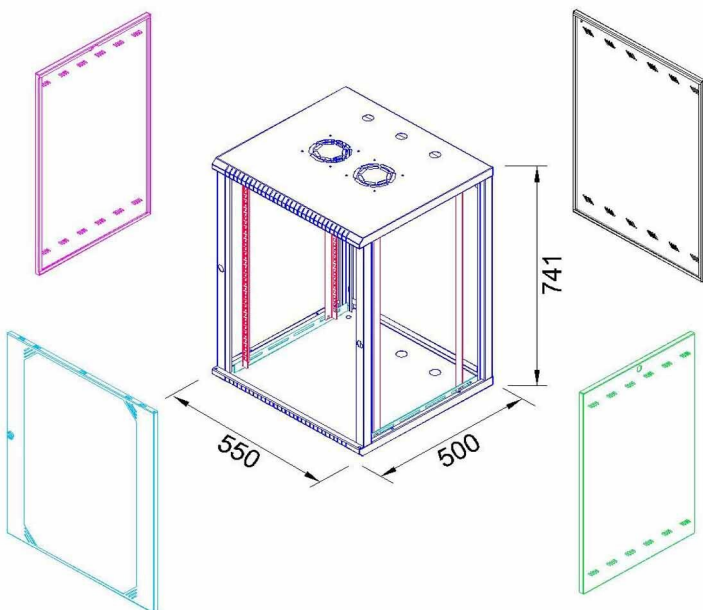

SPECIFICATION

Model No	MWM EXE 050 15
Capacity	15U
Width	550 mm
Depth	500 mm
Height	741 mm
Usable Depth	385 mm
Usable Height	681 mm
Mounting Width	518 mm
Mounting Height	625 mm